

I B. Tech II Semester Regular/Supplementary Examinations, August- 2022
NETWORK ANALYSIS
 (Com. To ECE, EIE, ECT)

Time: 3 hours

Max. Marks: 70

Answer any five Questions one Question from Each Unit
All Questions Carry Equal Marks

UNIT- I

- 1 a) Obtain the equivalent resistance at the terminals $a-b$ for the circuit shown? (7M)

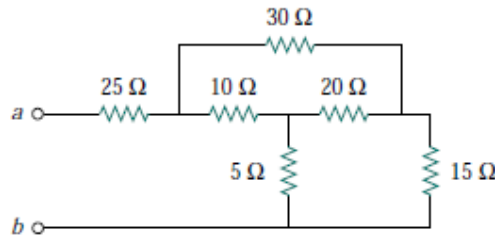

- b) Define Graph, Tree, Basic tie set matrix and cut set matrix for a planar network with an example? (7M)

Or

- 2 a) Use mesh analysis to find the current i_o in the circuit shown below. (7M)

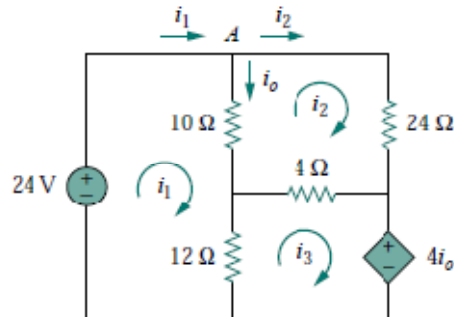

- b) Determine the RMS value of the current waveform shown below? If this current waveform is passed through 2Ω resistor, find the average power absorbed by the resistor? (7M)

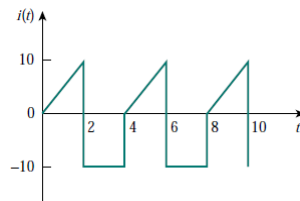

UNIT- II

- 3 a) A simple RL series circuit is excited by a sinusoidal voltage source. The circuit is initially relaxed. At $t=0$, the switch is closed find the response $i(t)$ for the current. Source voltage is $V_m \sin(\omega t + \phi)$ (7M)
- b) The capacitor in Fig. is initially charged to 3 V with the polarity shown. (i) Find the mathematical expressions for the voltage v_c and the current i_c when the switch is closed (ii) Sketch the waveforms for v_c and i_c . (7M)



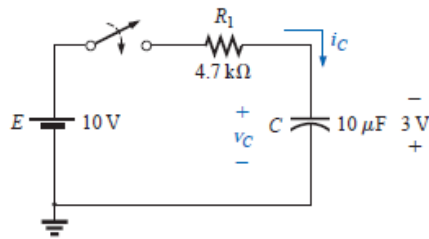

Or

- 4 a) Find $i(t)$ in the circuit of Fig. for $t > 0$. Assume that the switch has been closed for a long time. (7M)

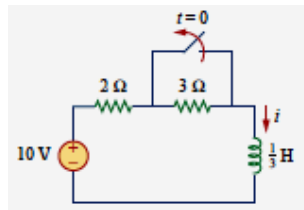

- b) Calculate the capacitor voltage for $t < 0$ and $t > 0$ for the circuit shown below. (7M)

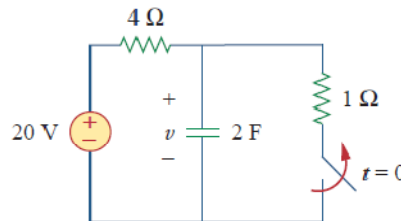

UNIT- III

- 5 a) A coil of inductance 318.3mH and negligible resistance is connected in series with a 200 Ω resistor to a 240 V, 50 Hz supply. Calculate (i) the inductive reactance of the coil (ii) the impedance of the circuit (iii) the current in the circuit (iv) the voltage across each component and (v) the circuit phase angle. (7M)
- b) When one coil of a magnetically coupled pair has a current 5.0 A the resulting fluxes ϕ_{11} and ϕ_{12} are 0.2 mWb and 0.4 mWb, respectively. If the turns are $N_1 = 500$ and $N_2 = 1500$, find L_1 , L_2 , M , and the coefficient of coupling k . (7M)

Or

- 6 a) Find the power factor of the circuit seen by the source for the network shown below. (7M)

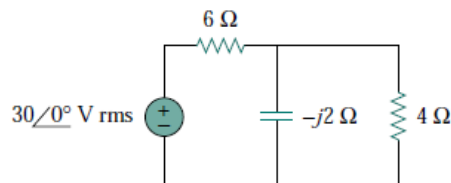

- b) Two coils are connected in series and their effective inductance is found to be 15 mH. When the connection to one coil is reversed, the effective inductance is found to be 10 mH. If the coefficient of coupling is 0.7, determine (i) the self-inductance of each coil, and (ii) the mutual inductance. (7M)



UNIT- IV

- 7 a) Design a series RLC circuit that will have an impedance of 10Ω & at the resonant frequency of $\omega_0 = 100 \text{ rad/s}$ and a quality factor of 80. Find the bandwidth. (7M)
 b) State and explain maximum power transfer theorem with an example? (7M)

Or

- 8 a) Apply the superposition principle to find i and power delivered to the 3Ω resistor in the circuit shown below? (7M)

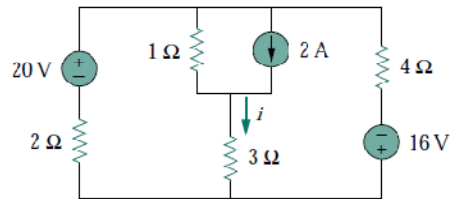

- b) Derive the expression for resonant frequency, band width and quality factor of a series resonant circuit? (7M)

UNIT- V

- 9 a) Obtain the ABCD parameters of the circuit shown below (7M)

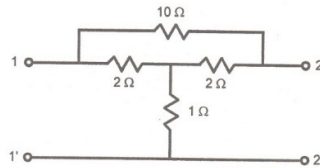

- b) Derive the relationship between hybrid and Z parameters of two port network? (7M)

Or

- 10 a) Determine the h parameters for the circuit shown below. (7M)

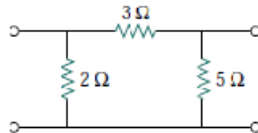

- b) Derive the relationship between transmission and Z parameters of two port network? (7M)



I B. Tech II Semester Regular/Supplementary Examinations, August- 2022
NETWORK ANALYSIS
 (ECE, EIE, ECT)

Time: 3 hours

Max. Marks: 70

Answer any five Questions one Question from Each Unit
All Questions Carry Equal Marks

UNIT-I

- 1 a) Find v_1 and v_2 in the circuit shown below. Also calculate i_1 and i_2 and the power dissipated in the $12\ \Omega$ and $40\ \Omega$ resistors. (7M)

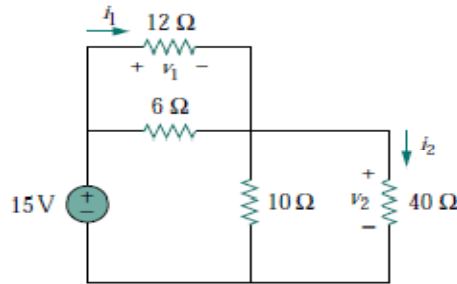

- b) Suppose your circuit laboratory has the following standard commercially available resistors in large quantities: $1.8\ \Omega$, $20\ \Omega$, $300\ \Omega$, $24\ \text{k}\Omega$, $56\ \text{k}\Omega$. Using series and parallel combinations and a minimum number of available resistors, how would you obtain the following resistances for an electronic circuit design?
 (i) $311.8\ \Omega$ (ii) $40\ \text{k}\Omega$

Or

- 2 a) For the bridge network shown in Fig., find R_{ab} and i . (7M)

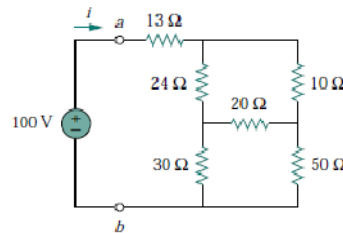

- b) Calculate the RMS value of the current wave form shown below? (7M)

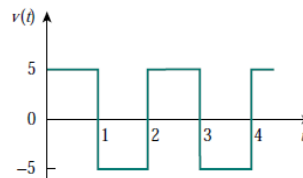

UNIT-II

- 3 a) Determine i , i_0 and v_o for $t > 0$ in the circuit shown in Fig. Assume that the switch was closed for a long time. (7M)

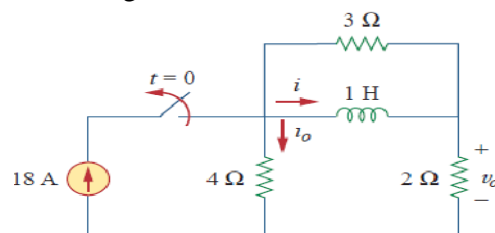

- b) Derive the expression for voltage response and current response of a series RC (7M) circuit with initially uncharged capacitor subjected to step input?

Or

- 4 a) Derive the expression for voltage response and current response of a series RL (7M) circuit with no initial inductor current subjected to step input?
 b) In Fig. shown the switch has been closed for a long time and is opened at $t = 0$. (7M) Find i and v for all time

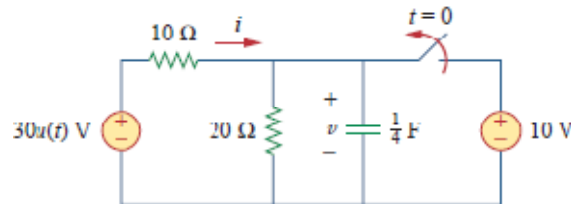

UNIT-III

- 5 a) A coil has a resistance of 4Ω and an inductance of 9.55 mH. Calculate (i) the reactance (ii) the impedance, and (iii) the current taken from a 240 V, 50 Hz supply. Also determine the phase angle between the supply voltage and current. (7M)
 b) The combined inductance of two coils connected in series is 0.6 H or 0.1 H (7M) depending on relative directions of currents in the two coils. If one of the coils has self-inductance of 0.2 H, find the mutual inductance and coefficient of coupling.

Or

- 6 a) Find I_0 in Fig. using mesh analysis? (7M)

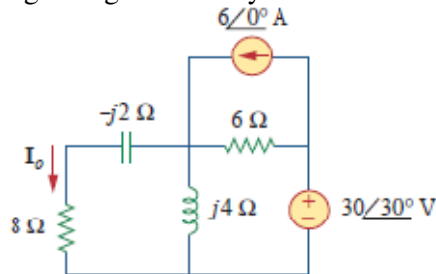

- b) Explain the principle of 'dot' rule used for the analysis of coupled circuits with an example? (7M)

UNIT-IV

- 7 a) State and explain thevenin's theorem with an example? (7M)
 b) For the series resonant circuit of Fig. find I , V_R , V_L , and V_C at resonance. What is the Q of the circuit? If the resonant frequency is 5000 Hz, find the bandwidth. What is the power dissipated in the circuit at the half-power frequencies? (7M)

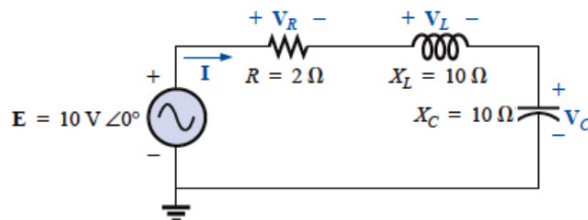

Or



- 8 a) State and explain Milliman's theorem? (7M)
 b) Find the maximum power that can be delivered to the resistor R in the circuit shown below. (7M)

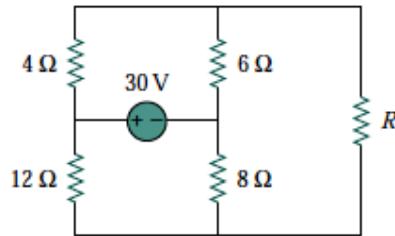

UNIT-V

- 9 Find the transmission parameters for the circuit shown below (14M)

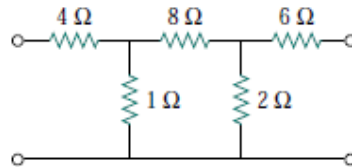

Or

- 10 a) Obtain the y parameters for the network shown in Fig. (7M)

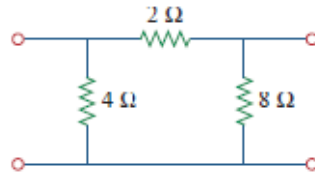

- b) Derive the relationship between hybrid and ABCD parameters of two port networks? (7M)



I B. Tech II Semester Regular/Supplementary Examinations, August- 2022
NETWORK ANALYSIS
 (ECE, EIE, ECT)

Time: 3 hours

Max. Marks: 70

Answer any five Questions one Question from Each Unit
All Questions Carry Equal Marks

UNIT-I

- 1 a) Calculate the node voltages in the circuit shown in Fig. (7M)

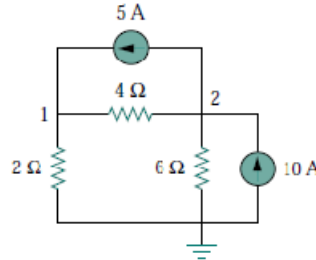

- b) Define basic cut-set and basic loop incidence matrices and write these for the following graph by taking 1, 2, 3 as tree branches as shown in Fig. (7M)

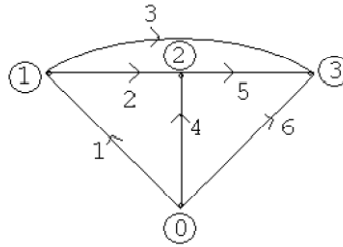

Or

- 2 a) Explain the principle of duality and draw the dual of the following network? (7M)

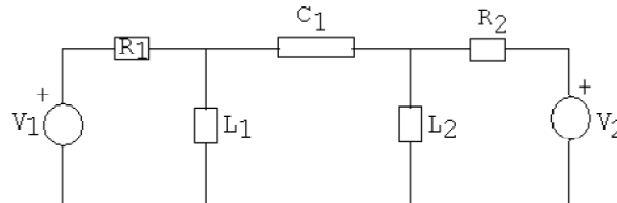

- b) Find the node voltages V_1 , V_2 , V_3 in the fig. shown below? (7M)

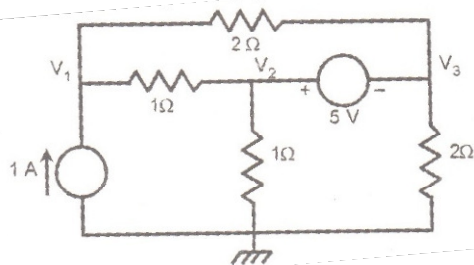
**UNIT-II**

- 3 a) Calculate the capacitor voltage for $t < 0$ and $t > 0$ for the circuit shown. (7M)



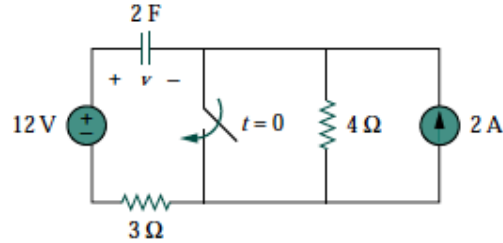

- b) The switch has been in position **a** for a long time. At $t=0$ it moves to position **b**. (7M)
Calculate $i(t)$ for all $t > 0$.

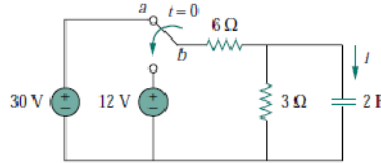

Or

- 4 a) In the circuit shown below, find $i(t)$ for $t > 0$ if $i(0) = 2$ A. (7M)

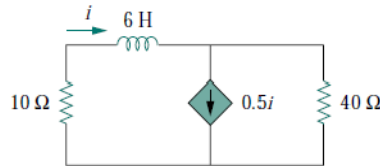

- b) The switch in Fig. 8.4 was open for a long time but closed at $t = 0$. Determine: (i) (7M)
 $i(0^+)$, $v(0^+)$ (ii) $di(0^+)/dt$, $dv(0^+)/dt$ (iii) $i(\infty)$, $v(\infty)$.

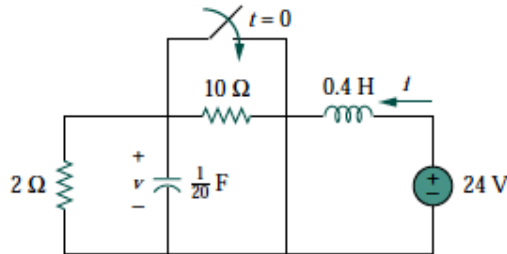

UNIT-III

- 5 a) Explain Star to delta conversion with relevant derivation? (7M)
b) Write short notes on dot convention used in magnetically coupled coils. Determine (7M)
the inductance of the three series connected inductors shown in Fig.

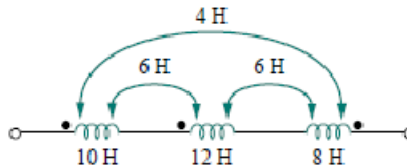

Or

- 6 a) A coil of resistance 5Ω and inductance 120mH in series with a $100\ \mu\text{F}$ capacitor, (7M)
is connected to a 300V , $50\ \text{Hz}$ supply. Calculate (i) the current flowing, (ii) the
phase difference between the supply voltage and current, (iii) the voltage across
the coil and (iv) the voltage across the capacitor.



- b) Obtain an expression for Co-efficient of coupling. (7M)

UNIT-IV

- 7 a) The bandwidth of a series resonant circuit is 400 Hz. (i) If the resonant frequency is 4000 Hz, what is the value of Q ? (ii) If $R = 10 \Omega$, what is the value of X_L at resonance (iii) Find the inductance L and capacitance C of the circuit. (7M)
- b) A series resonant circuit has a bandwidth of 100 Hz and contains a 20 mH inductance and a $2 \mu\text{F}$ capacitance. Determine (i) f_0 (ii) Q (iii) Z_{in} at resonance (iv) f_2 (7M)

Or

- 8 a) State and explain reciprocity theorem with an example? (7M)
- b) Obtain the Norton equivalent of the circuit in Fig. shown to the left of terminals a-b. Use the result to find current i . (7M)

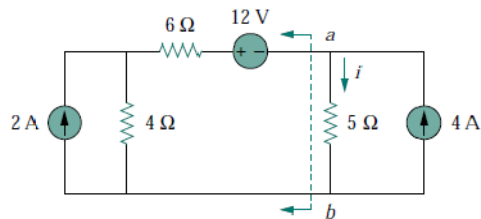

UNIT-V

- 9 a) Write a brief note on series and parallel connection of two port networks? (7M)
- b) Find the four short-circuit admittance parameters for the resistive two-port network shown (7M)

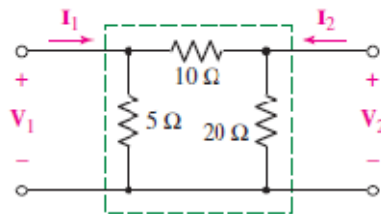

Or

- 10 a) Find the impedance parameters for the two-port shown in Fig. (7M)

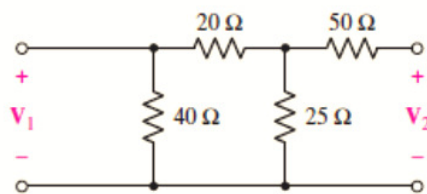

- b) Find the hybrid parameters for the circuit shown in Fig. (7M)

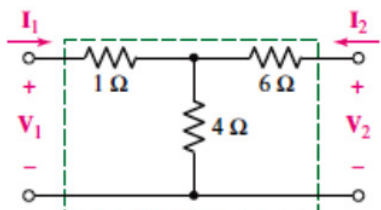

I B. Tech II Semester Regular/Supplementary Examinations, August- 2022
NETWORK ANALYSIS
 (ECE, EIE, ECT)

Time: 3 hours

Max. Marks: 70

Answer any five Questions one Question from Each Unit
All Questions Carry Equal Marks

UNIT-I

- 1 a) Obtain the equivalent resistance R_{ab} for the circuit shown below and use it to find current i . (7M)

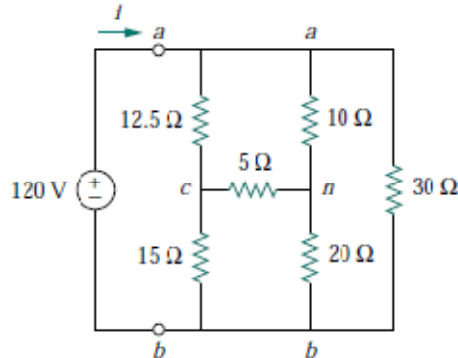

- b) For the arrangement shown, find (a) the equivalent capacitance of the circuit, (b) the voltage across Q_R and (c) the charge on each capacitor. (7M)

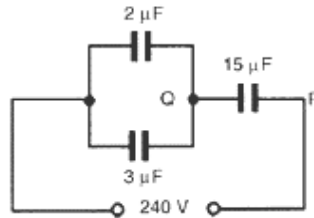

Or

- 2 a) For the bridge network shown, find i_o using mesh analysis. (7M)

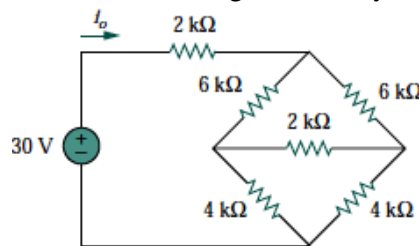

- b) For the graph shown, write the cut set schedule and obtain the relation between tree branch voltages and branch voltages. (7M)

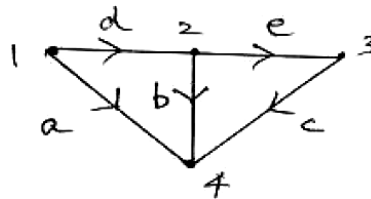

UNIT-II

- 3 a) Consider the circuit shown below. Find $i(t)$ for $t < 0$ and $t > 0$. (7M)

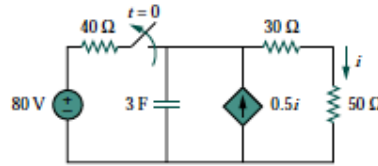

- b) Refer to the circuit shown in, Calculate: (7M)
 (i) $i_L(0+)$, $v_C(0+)$, and $v_R(0+)$ (ii) $i_L(\infty)$, $v_C(\infty)$, and $v_R(\infty)$.

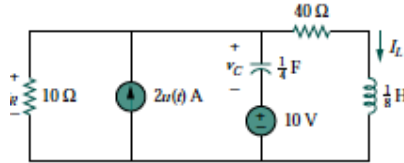

Or

- 4 a) An un-charged $80 \mu\text{F}$ capacitor is connected in series with a $1 \text{ k}\Omega$ resistor and is switched across a 110 V supply. Determine the time constant of the circuit and the initial value of current flowing. Also determine the value of current flowing after (a) 40 ms and (b) 80 ms (7M)
- b) Refer to the circuit shown below, the switch is closed at $t = 0$. (i) determine equations for i_L and v_L . (ii) At $t = 300 \text{ ms}$, open the switch and determine equations for i_L and v_L during the decay phase. (iii) Determine voltage and current at $t = 100 \text{ ms}$ and at $t = 350 \text{ ms}$. (iv) Sketch i_L and v_L (7M)

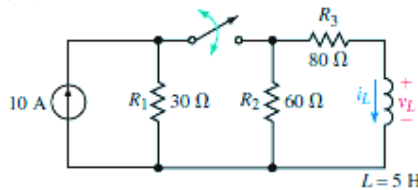

UNIT-III

- 5 a) A resistance of 50Ω is connected in series with a capacitance of $20 \mu\text{F}$. If a supply of $200\text{V}, 100 \text{ Hz}$ is connected across the arrangement find (i) the circuit impedance, (ii) the current flowing, and (iii) the phase angle between voltage and current (7M)
- b) Two identical coupled coils have an equivalent inductance of 80 mH when connected series aiding and 35 mH in series opposing. Find L_1 , L_2 , M and K . (7M)

Or

- 6 a) A resistance of 50Ω is connected in series with a capacitance of $20 \mu\text{F}$. If a supply of $200\text{V}, 100 \text{ Hz}$ is connected across the arrangement find (i) the circuit impedance, (ii) the current flowing, and (iii) the phase angle between voltage and current (7M)
- b) Define the following terms with an example (i) self-inductance (ii) Mutual inductance (iii) Coefficient of coupling (iv) Reluctance (7M)

UNIT-IV

- 7 a) For the circuit shown in Fig. (i). Determine the resonant frequency (ii) Find the voltage V_C at resonance (iii) Determine the currents I_L and I_C at resonance (iv) Find Quality factor. (7M)



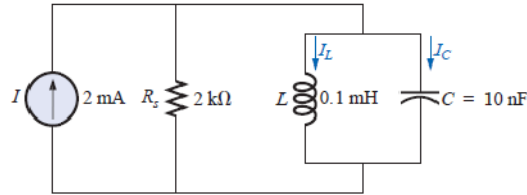

- b) For the network shown in Fig., find the value of R for maximum power to R, and determine the maximum power to R for each network. (7M)

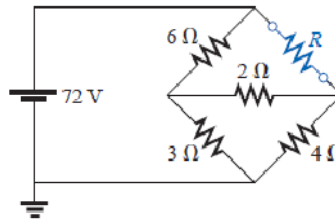

Or

- 8 a) Find the Thevenin equivalent circuit for the bridge network across the terminals a & b. Also find the current through the resistor of 1 Ω connected between a & b? (7M)

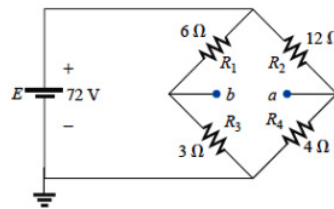

- b) State and explain Tellegen's theorem? (7M)

UNIT-V

- 9 a) Through derivation, express the Z parameters in terms of the ABCD parameters. (7M)
- b) If $h = \begin{pmatrix} 5 \Omega & 2 \\ -0.5 & 0.1 S \end{pmatrix}$ find admittance parameters? (7M)

Or

- 10 a) Prove that when two port networks are connected in parallel, the y parameters of the overall network are the sum of the y parameters of the individual networks (7M)
- b) For the two-port network shown in the Fig., the currents I_1 and I_2 entering at port 1 and 2 respectively are given by the equations. (7M)

$$I_1 = 0.5 V_1 - 0.2 V_2$$

$$I_2 = -0.2 V_1 + V_2$$

Where V_1 and V_2 are the port voltages at port 1 and 2 respectively. Find the Y and Z parameters for the network.

